

Tension Brakes/Air Cooled

ModEvo Tension Brakes

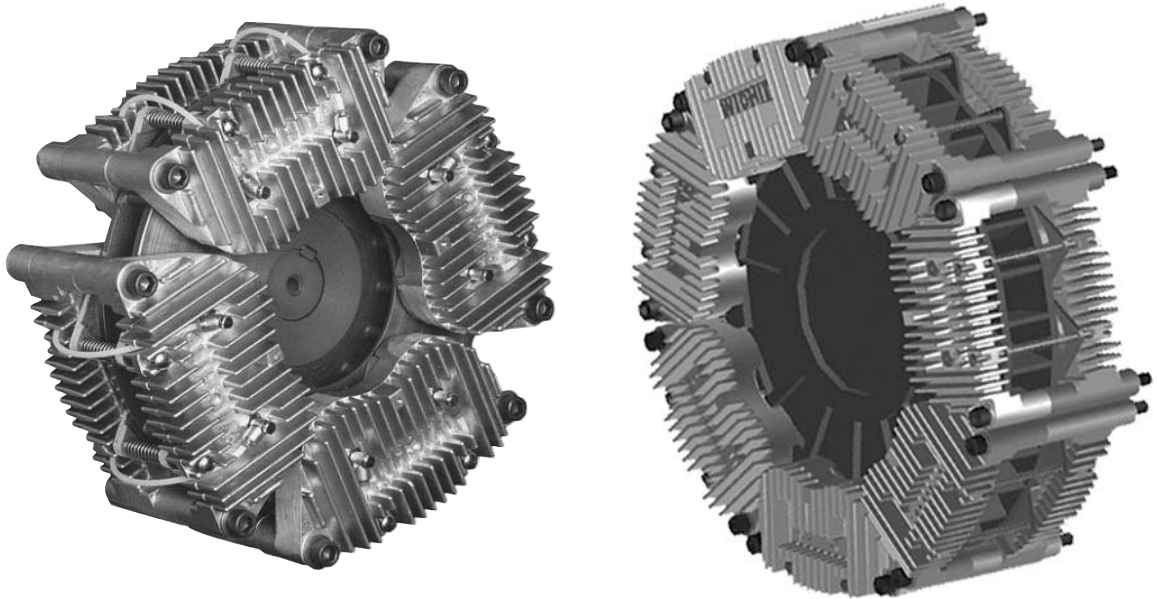

Brake Discs and Cooling

The ModEvo brake disc was developed at the Bedford, UK factory using Finite Element Analysis techniques to ensure maximum strength with minimum weight. The design is optimized to make best use of the cooling air available at slow speeds, and being bidirectional, it achieves high heat dissipation capacity in either rotational direction, unlike some other brakes. An optional electric cooling fan is available where space is limited or more extreme heat handling is required.

Available in five sizes: 250 mm, 300 mm, 350 mm, 400 mm and 450 mm diameters, all discs are the same thickness and use the same brake modules and actuators. Each disc can be specified with a minimum of a single module, up to the maximum number of modules that can be fitted

around the disc. This allows torque-handling capabilities ranging from a maximum of 659 lb.ft. for the 250 mm disc, up to 3181 lb.ft. for the 450 mm disc.

NOTE: If using a high speed ductile iron disc the catalog heat rating should be reduced by 10% as the thermal conductivity of the ductile iron is less than grey cast iron.

Maximum Rotational Speed		
Disc Diameter mm	Standard Speed rev./min.	High Speed rev./min.
250	2,250	3,375
300	1,900	2,850
350	1,650	2,475
400	1,450	2,175
450	1,250	1,875

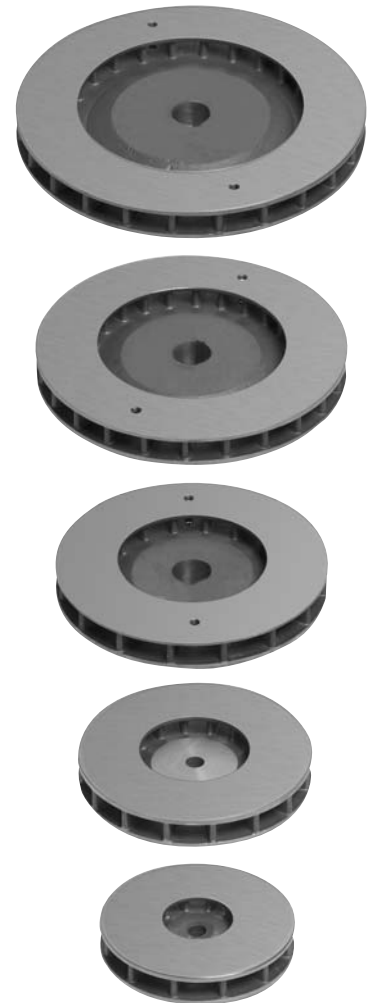

ModEvo Tension Brakes

Actuator Options

Newly developed rolling diaphragm actuators are used in ModEvo, producing more force than previous designs to allow higher torque ratings. However, the sensitivity for which rolling diaphragms are favored is not compromised. Three actuator options are available, offering clamping forces of 100%, 60% or 25%.

The finned, die cast aluminum brake module is common to all brake disc diameters. Each module houses two pairs of actuators, and allows friction pads to be changed quickly without dismantling the module.



100%



60%



25%

Friction Pad Options

To provide maximum flexibility when selecting the required torque/tension range for an application, two pad options are available, with different coefficients of frictions: Low ($\mu=0.20$), color-coded orange; Standard ($\mu=0.35$), color-coded grey. Pad types may be mixed within a single brake assembly to provide an exact match to the machine requirements.



Optional Guard

The optional guard has a plastic front with 'ModEvo' molded in and a metal ventilated perimeter.

Mounting is by four brackets on customer's machine frame.

The center of the guard is designed such that it may be cut-out by customer to suit the diameter of the shaft in through-shaft installations.

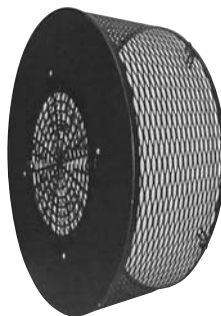

ModEvo 300/8 with Fan

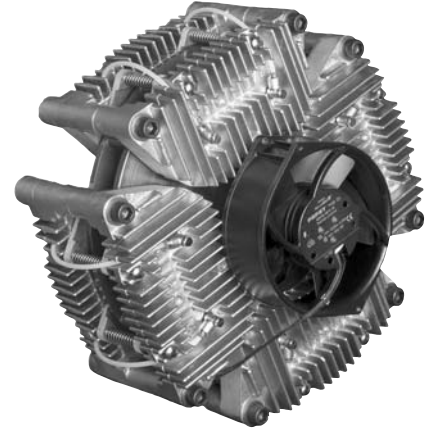

Brake Size (fan Diameter)	24v DC	115v AC	230v AC
250 (150 mm)	Yes	Yes	Yes
300 (150 mm)	Yes	Yes	Yes
350 (150 mm)	Yes	Yes	Yes
400 (150 mm)	Yes	Yes	Yes
(200 mm)	not available	Yes	Yes
450 (150 mm)	Yes	Yes	Yes
(200 mm)	not available	Yes	Yes
(250 mm)	not available	Yes	Yes

Tension Brakes/Air Cooled

ModEvo Tension Brakes

ModEvo Model 250

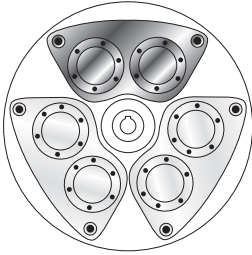

Model	Minimum Torques					
	Minimum (3 PSI) (0.2 Bars) ¹					
	lb.ft.(Nm)					
	LC ²	Std ³	LC ²	Std ³	LC ²	Std ³
	25% Actuators		60% Actuators		100 % Actuators	
250/1	0.6 (0.8)	0.93 (1.3)	1.3 (1.8)	2.2 (3)	2.2 (3)	3.7 (5)
250/2*	1.1 (1.5)	1.9 (2.5)	2.6 (3.6)	4.4 (6)	4.4 (6)	7.4 (10)
250/4*	2.2 (3)	3.7 (5)	5.3 (7.2)	8.8 (12)	8.8 (12)	14.7 (20)
250/6*	3.3 (4.5)	5.5 (7.5)	7.9 (10.8)	13.2 (18)	13.2 (18)	22 (30)

	Maximum Torques					
	Maximum (87 PSI) (6 Bars)					
	lb.ft.(Nm)					
250/1	15.8 (21.3)	27.5 (37.3)	37.8 (51)	66 (89.4)	63 (85)	110 (149)
250/2*	31.3 (42.5)	53.25 (72.3)	75 (102)	127.8 (173.4)	125 (170)	213 (298)
250/4*	62.8 (85)	110 (149)	150.6 (204)	264 (357.6)	251 (340)	440 (596)
250/6*	94 (127.5)	164.8 (223.5)	225.6 (306)	395.4 (536.4)	376 (510)	659 (894)

* For single actuator operation torques for 250/1 are applicable.

Model ⁶	Speed ⁴ Max. RPM	Heat Capacity for Effective Cooling Speeds								Inertia Rotating Parts lb.ft. ² (kbm ²)	Weight		
		Continuous Duty** HP(kW) ⁵									Total	Rotating	
		50 RPM	100 RPM	200 RPM	300 RPM	400 RPM	500 RPM	600 RPM	lbs.(kg)				
		Without Fan											
250/1	2250	1.34 (1.0)	1.61 (1.2)	2.14 (1.6)	2.68 (2.0)	3.08 (2.3)	3.49 (2.6)	3.62 (2.7)	1.424 (0.060)	27.337 (12.4)	19.180 (8.7)		
250/2	2250									29.101 (13.2)			
250/4	2250	With Electric Cooling Fan, 150 mm dia.										38.801 (17.6)	
250/6	2250	4.56 (3.4)	4.69 (3.5)	5.09 (3.8)	5.36 (4.0)	5.36 (4.0)	5.36 (4.0)	5.36 (4.0)		48.772 (22.1)			

** For intermittent duty, consult the factory.

¹ Minimum torques were calculated using a multiplier of 0.6 for LC times Standard.

² LC - Low Coefficient based on 0.2 Coefficient of friction.

³ Standard based on 0.35 Coefficient of friction.

⁴ Max. speed is with standard brake disc. A high speed brake disc capable of 50% higher speed is also available. Heat Capacity reduced by 10% when high speed disc is used.

⁵ Limit LC to 70% of heat capacity.

⁶ When selecting number of actuators, use a limit of 3.35 HP per actuator pair (2.5 kW per Actuator pair) for duty w/o fan and 3.75 HP per Actuator pair (2.8 kW per Actuator pair) when fan cooled.

Note: Limit maximum operating temperatures of surfaces (rotor, friction pads, actuators, etc.) to 300°F or less. Temperatures above 300°F may cause damage and failure of components. Failure to do so will void warranty.

Tension Brakes/Air Cooled

ModEvo Tension Brakes

ModEvo Model 300

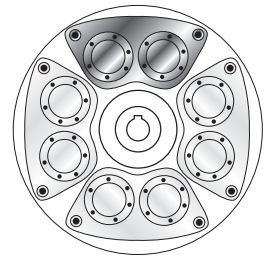

Model	Minimum Torques					
	Minimum (3 PSI) (0.2 Bars) ¹					
	lb.ft.(Nm)					
	LC ²	Std ³	LC ²	Std ³	LC ²	Std ³
	25% Actuators		60% Actuators		100 % Actuators	
300/1	0.7 (0.9)	1.1 (1.5)	1.6 (2.2)	2.6 (3.6)	2.6 (3.6)	5.2 (7)
300/2*	1.6 (2.1)	2.6 (3.5)	3.7 (5)	6.2 (8.4)	6.2 (8.4)	10.3 (14)
300/4*	3.1 (4.2)	5.2 (7)	7.4 (10.1)	12.4 (16.8)	12.4 (16.8)	20.6 (28)
300/6*	4.5 (6.3)	7.7 (10.5)	11.1 (15.1)	18.5 (25.2)	18.5 (25.2)	30.9 (42)
300/8*	6.2 (8.4)	10.3 (14)	14.9 (20.2)	24.8 (33.6)	24.8 (33.6)	41.3 (56)

	Maximum Torques					
	Maximum (87 PSI) (6 Bars)					
lb.ft.(Nm)						
300/1	19.8 (27)	34.9 (47.3)	47.4 (64.8)	83.6 (113.4)	79 (108)	139.4 (189)
300/2*	39.8 (54)	69.7 (94.5)	95.4 (129.6)	167.3 (226.8)	159 (216)	278.8 (378)
300/4*	79.5 (108)	139.4 (189)	190.8 (259.2)	334.6 (453.6)	318 (432)	557.6 (756)
300/6*	119.3 (162)	209.1 (283.5)	286.2 (388.8)	501.8 (680.4)	477 (648)	836.4 (1,134)
300/8*	159.3 (216)	278.8 (378)	382.2 (518.4)	669 (907.2)	637 (864)	1,115 (1,512)

* For single actuator operation torques for 300/1 are applicable.

Model ⁶	Speed ⁴ Max. RPM	Heat Capacity for Effective Cooling Speeds								Inertia Rotating Parts lb.ft. ² (kbrn ²)	Weight	
		Continuous Duty** HP(kW) ⁵									Total	Rotating
		50 RPM	100 RPM	200 RPM	300 RPM	400 RPM	500 RPM	600 RPM	lbs.(kg)			
300/1	1900	Without Fan								2.966 (0.125)	38.140 (17.3)	29.883 (13.6)
300/2	1900	2.41 (1.8)	2.68 (2.0)	3.35 (2.5)	4.02 (3.0)	4.56 (3.4)	5.09 (3.8)	5.63 (4.2)	39.904 (18.1)			
300/4	1900	With Electric Cooling Fan, 150 mm dia.									49.604 (22.5)	
300/6	1900	6.30 (4.7)	6.70 (5.0)	6.70 (5.0)	6.70 (5.0)	7.37 (5.5)	8.04 (6.0)	8.04 (6.0)	59.525 (27.0)			
300/8	1900										69.446 (31.5)	

** For intermittent duty, consult the factory.

¹ Minimum torques were calculated using a multiplier of 0.6 for LC times Standard.

² LC - Low Coefficient based on 0.2 Coefficient of friction.

³ Standard based on 0.35 Coefficient of friction.

⁴ Max. speed is with standard brake disc. A high speed brake disc capable of 50% higher speed is also available. Heat Capacity reduced by 10% when high speed disc is used.

⁵ Limit LC to 70% of heat capacity.

⁶ When selecting number of actuators, use a limit of 3.35 HP per actuator pair (2.5 kW per Actuator pair) for duty w/o fan and 3.75 HP per Actuator pair (2.8 kW per Actuator pair) when fan cooled.

Note: Limit maximum operating temperatures of surfaces (rotor, friction pads, actuators, etc.) to 300°F or less.

Temperatures above 300°F may cause damage and failure of components. Failure to do so will void warranty.

Tension Brakes/Air Cooled

ModEvo Tension Brakes

ModEvo Model 350

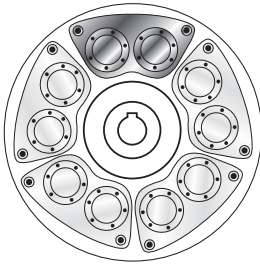

Model	Minimum Torques					
	Minimum (3 PSI) (0.2 Bars) ¹ lb.ft.(Nm)					
	LC ²	Std ³	LC ²	Std ³	LC ²	Std ³
	25% Actuators		60% Actuators		100 % Actuators	
350/1	0.9 (1.2)	1.5 (2)	2.1 (2.9)	3.5 (4.8)	3.5 (4.8)	5.9 (8)
350/2*	1.8 (2.4)	3.0 (4)	4.3 (5.8)	7.1 (9.6)	7.1 (9.6)	11.8 (16)
350/4*	3.6 (4.8)	5.9 (8)	8.5 (11.5)	14.2 (19.2)	14.2 (19.2)	23.6 (32)
350/6*	5.3 (7.2)	8.9 (12)	12.7 (17.3)	21.2 (28.8)	21.2 (28.8)	35.4 (48)
350/8*	7.1 (9.6)	11.8 (16)	17 (9.6)	28.3 (38.4)	28.3 (38.4)	47.2 (64)
350/10*	8.9 (12)	14.8 (20)	21.2 (28.8)	35.4 (48)	35.4 (48)	59.0 (80)

Model	Maximum Torques					
	Maximum (87 PSI) (6 Bars) lb.ft.(Nm)					
	LC ²	Std ³	LC ²	Std ³	LC ²	Std ³
350/1	24 (32.5)	42 (57)	57.55 (78)	101 (137)	95.9 (130)	168 (228)
350/2*	48 (65)	84.1 (114)	115.1 (156)	201.8 (273.6)	191.8 (260)	336.4 (456)
350/4*	95.9 (130)	168.2 (228)	230.2 (312)	403.6 (547.2)	383.6 (520)	672.7 (912)
350/6*	143.8 (195)	252.3 (342)	345.2 (468)	605.4 (820.8)	575.3 (780)	1009 (1,368)
350/8*	190.5 (260)	336.4 (456)	457.3 (624)	807.2 (1,094.4)	762.1 (1,040)	1,345.4 (1,824)
350/10*	239.7 (325)	420.4 (570)	575.3 (780)	1,009 (1,368)	9,58.9 (1,300)	1,681.7 (2,280)

* For single actuator operation torques for 350/1 are applicable.

Model ⁶	Speed ⁴ Max. RPM	Heat Capacity for Effective Cooling Speeds								Inertia Rotating Parts lb.ft. ² (kbm ²)	Weight	
		Continuous Duty** HP(kW) ⁵									Total	Rotating
		50 RPM	100 RPM	200 RPM	300 RPM	400 RPM	500 RPM	600 RPM	lbs.(kg)			
350/2	1650	Without Fan								5.458 (0.230)	57.982 (24.8)	46.958 (20.3)
350/4	1650	3.22 (2.4)	3.49 (2.6)	4.69 (3.5)	5.36 (4.0)	6.17 (4.6)	7.37 (5.5)	8.04 (6.0)	69.005 (29.2)			
350/6	1650	With Electric Cooling Fan, 150 mm dia.									80.248 (33.7)	
350/8	1650	7.77 (5.8)	8.45 (6.3)	8.71 (6.5)	8.71 (6.5)	8.71 (6.5)	8.71 (6.5)	8.71 (6.5)	91.271 (38.2)			
350/10	1650										102.294 (42.7)	

** For intermittent duty, consult the factory.

¹ Minimum torques were calculated using a multiplier of 0.6 for LC times Standard.

² LC - Low Coefficient based on 0.2 Coefficient of friction.

³ Standard based on 0.35 Coefficient of friction.

⁴ Max. speed is with standard brake disc. A high speed brake disc capable of 50% higher speed is also available. Heat Capacity reduced by 10% when high speed disc is used.

⁵ Limit LC to 70% of heat capacity.

⁶ When selecting number of actuators, use a limit of 3.35 HP per actuator pair (2.5 kW per Actuator pair) for duty w/o fan and 3.75 HP per Actuator pair (2.8 kW per Actuator pair) when fan cooled.

Note: Limit maximum operating temperatures of surfaces (rotor, friction pads, actuators, etc.) to 300°F or less.

Temperatures above 300°F may cause damage and failure of components. Failure to do so will void warranty.

Tension Brakes/Air Cooled

ModEvo Tension Brakes

ModEvo Model 400

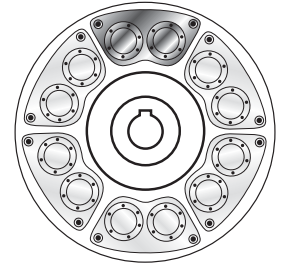

Model	Minimum Torques					
	Minimum (3 PSI) (0.2 Bars) ¹ lb.ft.(Nm)					
	LC ²	Std ³	LC ²	Std ³	LC ²	Std ³
	25% Actuators		60% Actuators		100 % Actuators	
400/1	1.1 (1.5)	1.9 (2.5)	2.6 (3.6)	4.4 (6)	4.4 (6)	7.4 (10)
400/2*	2.2 (3)	3.7 (5)	5.3 (7.2)	8.9 (12)	8.9 (12)	14.8 (20)
400/4*	4.4 (6)	7.4 (10)	10.6 (14.4)	17.7 (24)	17.7 (24)	29.5 (40)
400/6*	6.7 (9)	11.1 (15)	16 (21.6)	26.6 (36)	26.6 (36)	44.3 (60)
400/8*	8.9 (12)	14.8 (20)	21.2 (28.8)	35.4 (48)	35.4 (48)	59.0 (80)
400/10*	11.1 (15)	18.5 (25)	26.6 (36)	44.3 (60)	44.3 (60)	73.8 (100)
400/12*	13.3 (18)	22.1 (30)	31.9 (43.2)	53.1 (72)	53.1 (72)	88.5 (120)

Maximum Torques						
Maximum (87 PSI) (6 Bars) lb.ft.(Nm)						
400/1	28.15 (38.15)	49.2 (66.7)	67.5 (91.5)	118 (160)	112.5 (152.5)	196.9 (267)
400/2*	56.3 (76.3)	98.3 (133.5)	135 (183)	236 (320.4)	225 (305)	393.9 (534)
400/4*	112.5 (152.5)	197 (267)	270 (366)	472.7 (640.8)	450 (610)	787.8 (1,068)
400/6*	168.7 (228.8)	295.4 (400.5)	404.9 (549)	708.9 (961.2)	674.9 (915)	1,181.9 (1,602)
400/8*	225 (305)	393.9 (534)	539.9 (732)	945.3 (1,281.6)	899.9 (1,220)	1,575.5 (2,136)
400/10*	281.2 (381.3)	492.4 (667.5)	674.9 (915)	1,181.6 (1,602)	1,124.8 (1,525)	1,969.4 (2,670)
400/12*	337.5 (457.5)	590.8 (801)	809.9 (1,098)	1,417.9 (1,922.4)	1,349.8 (1,830)	2,363.3 (3,204)

* For single actuator operation torques for 400/1 are applicable.

Model ⁶	Speed ⁴ Max. RPM	Heat Capacity for Effective Cooling Speeds							Inertia Rotating Parts lb.ft. ² (kNm ²)	Weight	
		Continuous Duty** HP(kW) ⁵								Total	Rotating
		50 RPM	100 RPM	200 RPM	300 RPM	400 RPM	500 RPM	600 RPM			
400/2	1450								9.492 (0.400)	69.005 (31.3)	61.509 (26.8)
400/4	1450	Without Fan								78.705 (35.7)	
400/6	1450	3.62 (2.7)	4.29 (3.2)	6.03 (4.5)	6.70 (5.0)	7.64 (5.7)	8.71 (6.5)	9.38 (7.0)		88.626 (40.2)	
400/8	1450	With Electric Cooling Fan, 150 mm dia.								98.547 (44.7)	
400/10	1450	8.18 (6.1)	8.98 (6.7)	9.38 (7.0)	10.05 (7.5)	10.72 (8.0)	10.72 (8.0)	10.72 (8.0)		108.467 (49.2)	
400/12	1450									118.168 (53.6)	

**For intermittent duty and thermal ratings using 200 mm fan, consult the factory.

¹ Minimum torques were calculated using a multiplier of 0.6 for LC times Standard.

² LC - Low Coefficient based on 0.2 Coefficient of friction.

³ Standard based on 0.35 Coefficient of friction.

⁴ Max. speed is with standard brake disc. A high speed brake disc capable of 50% higher speed is also available. Heat Capacity reduced by 10% when high speed disc is used.

⁵ Limit LC to 70% of heat capacity.

⁶ When selecting number of actuators, use a limit of 3.35 HP per actuator pair (2.5 kW per Actuator pair) for duty w/o fan and 3.75 HP per Actuator pair (2.8 kW per Actuator pair) when fan cooled.

Note: Limit maximum operating temperatures of surfaces (rotor, friction pads, actuators, etc.) to 300°F or less.

Temperatures above 300°F may cause damage and failure of components. Failure to do so will void warranty.

Tension Brakes/Air Cooled

ModEvo Tension Brakes

ModEvo Model 450

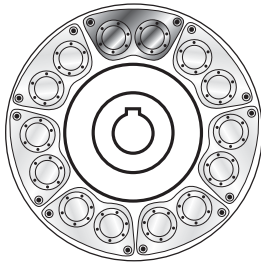

Model	Minimum Torques					
	Minimum (3 PSI) (0.2 Bars) ¹ lb.ft.(Nm)					
	LC ²	Std ³	LC ²	Std ³	LC ²	Std ³
	25% Actuators		60% Actuators		100 % Actuators	
450/1	1.2 (1.7)	2.0 (2.8)	2.9 (4.0)	4.9 (6.6)	4.9 (6.6)	8.1 (11)
450/2*	2.3 (3.2)	3.9 (5.3)	5.6 (7.6)	9.3 (12.6)	9.3 (12.6)	15.5 (21)
450/4*	4.7 (6.3)	7.8 (10.5)	11.2 (15.1)	18.6 (25.2)	18.6 (25.2)	31.0 (42)
450/6*	7 (9.5)	11.6 (37.8)	16.7 (22.7)	27.9 (37.8)	27.9 (37.8)	46.5 (63)
450/8*	9.3 (12.6)	15.7 (15.5)	22.3 (30.2)	37.7 (50.4)	37.2 (50.4)	62.0 (84)
450/10*	11.6 (15.8)	19.4 (26.3)	27.9 (37.8)	46.5 (63)	46.5 (63)	77.5 (105)
450/12*	13.9 (18.9)	23.2 (31.5)	33.4 (45.4)	55.7 (75.6)	55.7 (75.6)	92.9 (126)
450/14*	13.6 (22.1)	27.1 (27.1)	39 (52.9)	65 (88.2)	65 (88.2)	108.4 (147)

	Maximum Torques					
	Maximum (87 PSI) (6 Bars) lb.ft.(Nm)					
450/1	32.45 (44)	56.7 (77)	77.9 (105.6)	136.3 (189.8)	129.8 (176)	227.2 (308)
450/2*	64.9 (88)	113.6 (154)	155.8 (211.2)	272.6 (369.6)	259.6 (352)	454.4 (616)
450/4*	129.8 (176)	227.2 (308)	311.6 (422.4)	545.2 (739.2)	519.3 (704)	908.7 (1,232)
450/6*	194.7 (264)	340.8 (462)	467.3 (633.6)	817.9 (1,108.8)	778.9 (1,056)	1,363.1 (1,848)
450/8*	259.6 (352)	454.4 (616)	623.1 (844.8)	1,090.4 (1,478.4)	1,038.5 (1,408)	1,817.4 (2,464)
450/10*	324.6 (440)	568 (770)	778.9 (1,056)	1,363.1 (1,848)	1,298.2 (1,760)	2,271.8 (3,080)
450/12*	389.5 (528)	681.6 (924)	934.7 (1,267.2)	1,635.7 (2,217.6)	1,557.8 (2,112)	2,726.2 (3,696)
450/14*	454.4 (616)	795.1 (1,078)	1,090.4 (1,478.4)	1,908.3 (2,587.2)	1,817.4 (2,464)	3,180.5 (4,312)

* For single actuator operation torques for 450/1 are applicable.

Model ⁶	Speed ⁴ Max. RPM	Heat Capacity for Effective Cooling Speeds							Inertia Rotating Parts lb.ft. ² (kgm ²)	Weight	
		Continuous Duty** HP(kW) ⁵								Total	Rotating
		50 RPM	100 RPM	200 RPM	300 RPM	400 RPM	500 RPM	600 RPM			
450/2	1250								14.475 (0.610)	82.673 (37.5)	72.752 (33.0)
450/4	1250	Without Fan								92.374 (41.9)	
450/6	1250	3.89 (2.9)	4.83 (3.6)	6.84 (5.1)	7.91 (5.9)	8.71 (6.5)	10.32 (7.7)	11.13 (8.3)		102.294 (46.4)	
450/8	1250	With Electric Cooling Fan, 150 mm dia.								112.215 (50.9)	
450/10	1250	8.85 (6.6)	9.12 (6.8)	9.38 (7.0)	9.65 (7.2)	10.72 (8.0)	11.66 (8.7)	12.47 (9.3)		122.136 (55.4)	
450/12	1250									131.836 (59.8)	
450/14	1250									141.757 (64.3)	

**For intermittent duty and thermal ratings using 200 mm or 250 mm fan, consult the factory.

¹ Minimum torques were calculated using a multiplier of 0.6 for LC times Standard.

² LC - Low Coefficient based on 0.2 Coefficient of friction.

³ Standard based on 0.35 Coefficient of friction.

⁴ Max. speed is with standard brake disc. A high speed brake disc capable of 50% higher speed is also available. Heat Capacity reduced by 10% when high speed disc is used.

⁵ Limit LC to 70% of heat capacity.

⁶ When selecting number of actuators, use a limit of 3.35 HP per actuator pair (2.5 kW per Actuator pair) for duty w/o fan and 3.75 HP per Actuator pair (2.8 kW per Actuator pair) when fan cooled.

Note: Limit maximum operating temperatures of surfaces (rotor, friction pads, actuators, etc.) to 300°F or less. Temperatures above 300°F may cause damage and failure of components. Failure to do so will void warranty.

ModEvo Tension Brakes

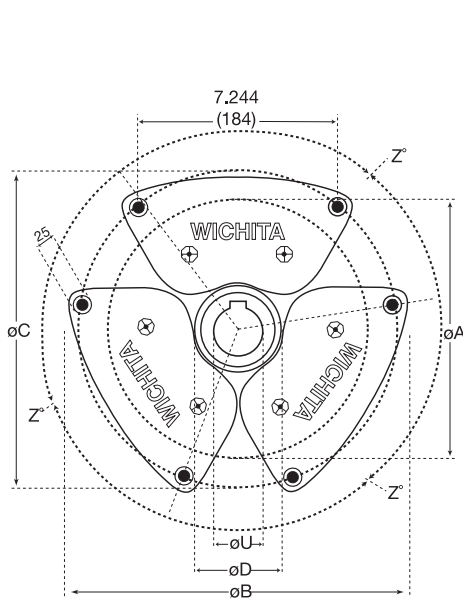

Front View

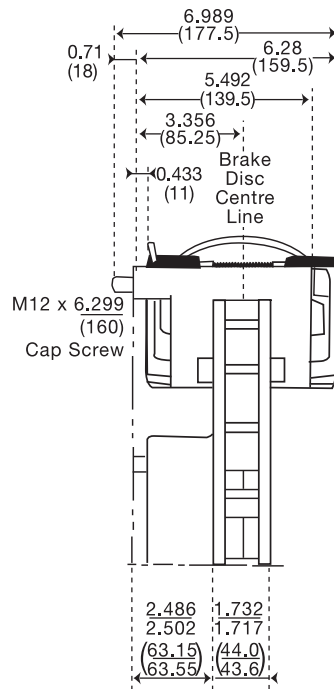

Side View

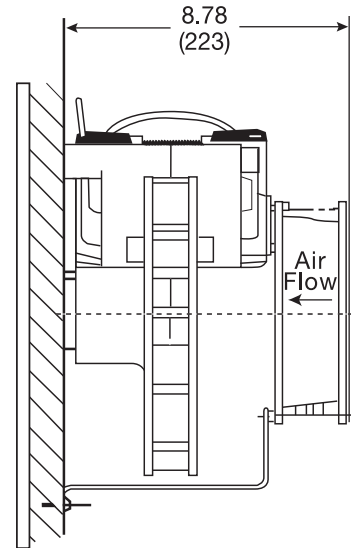

Side View With Fan

Dimensions: inches (mm)

Size	250	300	350	400	450
ØA - Disc Size	9.843 (250)	11.811 (300)	13.78 (350)	15.748 (400)	17.717 (450)
ØB - Overall	12.756 (324)	14.528 (369)	16.339 (415)	18.149 (461)	20.000 (508)
ØC - Bolt P.C.D	11.752 (298.5)	13.524 (343.5)	15.315 (389)	17.146 (435.5)	18.996 (482.5)
ØD - Clearance Diameter	3.543 (90)	5.512 (140)	7.480 (190)	9.449 (240)	11.417 (290)
U - As Cast Bore	0.984 (25)	0.984 (25)	0.984 (25)	0.984 (25)	0.984 (25)
Maximum Bore	2.165 (55)	3.110 (79)	4.606 (117)	5.354 (136)	6.063 (154)
Z" - Angular Position	120°	90°	72°	60°	51.4°
Maximum Number of Brake Modules	3	4	5	6	7
Wichita Generic Drawing Number	73125-000	73130-000	73141-000	73141-000	73145-000
Hose Length/Module 15667-020 W4 6977	39.37 (1,000)	47.25 (1,200)	55.12 (1,400)	63.00 (1,600)	70.87 (1,800)