

STANDARD IB INLINE CLUTCH IB314IL

QUALITY IS STANDARD

- OPTIONAL SINTERED IRON PLATES
- BUILT IN HEX NUT
- VENTILATED CENTER PLATES & DRIVING RING
- SEALED FOR LIFE PILOT BEARING
- CREATES 25% HIGHER TORQUE CAPACITY
- EASES ADJUSTMENT VERIFICATION
- IMPROVED HEAT DISSIPATION
- LESS MAINTENANCE



SPECIFICATIONS - IB314IL1

Model Number	SAE HSG.	Dimension "A" mm (in)	Max. Input Torque Nm (lb-ft)		Maximum Safe Speed	Weight kg (lbs)
			Organic	Sintered		
IB314IL1	1	100 (3.94)	3297 (2430)	4125 (3040)	2400	271 (595)
IB314IL1	1	80 (3.14)			2400	271 (595)

LOAD CLASSIFICATIONS BASED UPON AGMA LOAD CHARACTERISTICS

PRIME MOVER	DURATION OF SERVICE	DRIVEN MACHINE LOAD CLASSIFICATIONS		
		UNIFORM	MODERATE SHOCK	HEAVY SHOCK
Electric motor	Up to 3 hours per day	1.00	1.25	1.50
	3-10 hours per day	1.00	1.25	1.75
	Over 10 hours per day	1.25	1.50	2.00
Multi-cylinder internal combustion engine	Up to 3 hours per day	1.00	1.25	1.75
	3-10 hours per day	1.25	1.50	2.00
	Over 10 hours per day	1.50	1.75	2.25
Multi-cylinder internal combustion engine with high torque rise	Up to 3 hours per day	1.50	1.75	2.25
	3-10 hours per day	1.75	2.00	2.50
	Over 10 hours per day	2.00	2.25	2.75
Single cylinder internal combustion engine	Up to 3 hours per day	1.25	1.50	2.00
	3-10 hours per day	1.50	1.75	2.25
	Over 10 hours per day	1.75	2.00	2.50

All clutch engagements to be with prime mover below 1000 RPM. High inertia loads may require use of larger clutch. Contact Twin Disc application engineering department for assistance.

TO CALCULATE APPLICATION TORQUE:

$$\frac{5252 \times \text{HP}}{\text{Engine RPM}} = \text{Torque}$$

$$\text{Torque} \times \text{Load Factor} = \text{Application Torque}$$

Use load factor from chart at left

Specifications subject to change without prior notice in the interest of continual product improvement. Contact your local Twin Disc representative for engineering specifications.



IB314IL

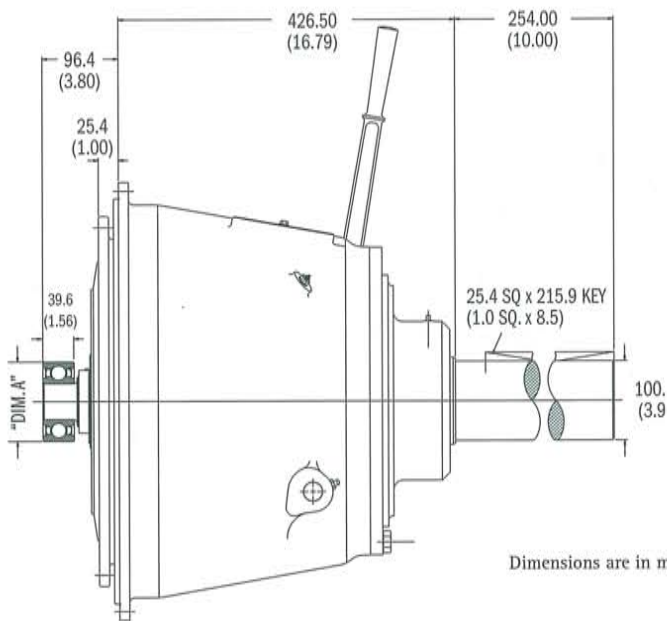

For nearly a century, we've been putting horsepower to work by designing, engineering and manufacturing rugged-duty industrial products. Our products and our reputation are bolted to the most renowned engine manufacturers and equipment OEMs in the world. Our mission is to make your machines and vehicles more productive, more durable, more operator-friendly, more cost-effective. From design and installation consultation through after-sale support, Twin Disc and its distributors are committed to your business. No one knows more about managing horsepower in more ways than Twin Disc.

TRANSMISSIONS • CLUTCHES • PTOS
PUMP DRIVES • TORQUE CONVERTERS
GEARBOXES • HYDRAULIC PTO PRODUCTS



Twin Disc, Incorporated
Racine, Wisconsin 53403 USA
Phone +1-262-638-4000
Fax +1-262-638-4482
www.twindisc.com

Twin Disc, incorporated reminds users of these products that their safe operation depends on use in compliance with engineering information provided. Users are also reminded that safe operation depends on proper installation, operation and routine maintenance and inspection under prevailing conditions. It is the responsibility of users (and not Twin Disc, Incorporated) to provide and install guards or safety devices which may be required by recognized safety standards or by the Occupational Safety and Health Act of 1970 and its subsequent provisions.

United States of America • Australia • Belgium • France • Italy • Singapore • Switzerland

TD-Bulletin-IB314ILSeries
© 2007, Twin Disc, Incorporated
Printed in the USA - 05/2007