

## STANDARD SP CLUTCH SP314S

### QUALITY IS STANDARD

- STRADDLE BEARING DESIGN
- NO PILOT
- BALL BEARING THROW OUT
- OPTIONAL SINTERED IRON PLATES
- BUILT IN HEX NUT
- ALLOWS FOR MAXIMUM SIDE LOAD CAPACITY
- EASE OF INSTALLATION
- ALLOWS FOR MORE FREQUENT ENGAGEMENTS
- CREATES 25% HIGHER TORQUE CAPACITY
- EASES ADJUSTMENT VERIFICATION



### SPECIFICATIONS - SP314S

Model Number	SAE HSG.	Max. Input Torque Nm (lb-ft)		Maximum Safe Speed	Weight kg (lbs)
		Organic	Sintered		
SP314S	1	3297 (2430)	4125 (3040)	3000	261 (575)

### LOAD CLASSIFICATIONS BASED UPON AGMA LOAD CHARACTERISTICS

PRIME MOVER	DURATION OF SERVICE	DRIVEN MACHINE LOAD CLASSIFICATIONS		
		UNIFORM	MODERATE SHOCK	HEAVY SHOCK
Electric motor	Up to 3 hours per day	1.00	1.25	1.50
	3-10 hours per day	1.00	1.25	1.75
	Over 10 hours per day	1.25	1.50	2.00
Multi-cylinder internal combustion engine	Up to 3 hours per day	1.00	1.25	1.75
	3-10 hours per day	1.25	1.50	2.00
	Over 10 hours per day	1.50	1.75	2.25
Multi-cylinder internal combustion engine with high torque rise	Up to 3 hours per day	1.50	1.75	2.25
	3-10 hours per day	1.75	2.00	2.50
	Over 10 hours per day	2.00	2.25	2.75
Single cylinder internal combustion engine	Up to 3 hours per day	1.25	1.50	2.00
	3-10 hours per day	1.50	1.75	2.25
	Over 10 hours per day	1.75	2.00	2.50

All clutch engagements to be with prime mover below 1000 RPM. High inertia loads may require use of larger clutch. Contact Twin Disc application engineering department for assistance.

### TO CALCULATE APPLICATION TORQUE:

$$\frac{5252 \times \text{HP}}{\text{Engine RPM}} = \text{Torque}$$

$$\text{Torque} \times \text{Load Factor} = \text{Application Torque}$$

Use load factor from chart at left

**SP314S**

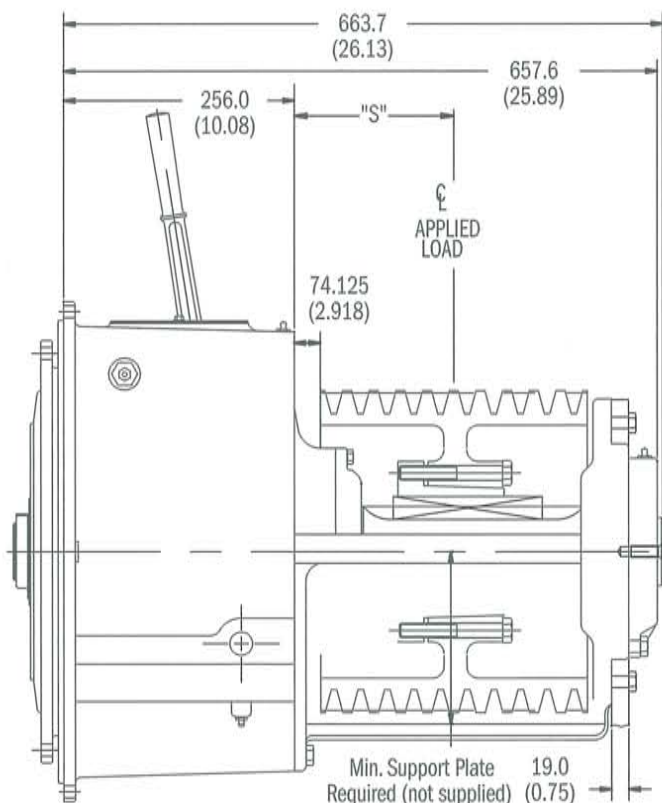

Dimensions are in mm (inches)

**STANDARD AND STRETCH SIDE LOAD CAPACITY VALUES**

S DIMENSION mm (in)	2400 RPM MAX. LOAD Nm (lbs)	2100 RPM MAX. LOAD Nm (lbs)	1800 RPM MAX. LOAD Nm (lbs)	1500 RPM MAX. LOAD Nm (lbs)
127.0 (5.0)	40744 (9160)	42478 (9550)	44480 (10000)	47149 (10600)
152.4 (6.0)	45814 (10300)	47816 (10750)	50040 (11250)	52931 (11900)
177.8 (7.0)	52486 (11800)	54488 (12250)	56934 (12800)	60493 (13600)
203.2 (8.0)	56934 (12800)	59158 (13300)	61827 (13900)	65386 (14700)
228.6 (9.0)	49595 (11150)	51597 (11600)	54043 (12150)	56934 (12800)
254.0 (10.0)	44035 (9900)	45814 (10300)	47816 (10750)	50485 (11350)

The following general formula should be used for determining the actual applied load:  $L = \frac{126,000 \times \text{HP}}{N \times D} \times F \times \text{LF}$

- WHERE
- L = Actual Applied Load (lbs)
  - N = Shaft Speed (RPM)
  - D = Pitch Diameter (in) of Sheave, etc.
  - F = Load Factor
  - 1.0 for Chain or Gear Drive, 1.5 for Timing Belts, 2.5 for All V Belts, 3.5 for Flat Belts
  - LF = 2.1 for Reciprocating Compressors and other Severe Shock Drives and 1.8 for Large Inertia Type Drives (i.e. crushers, chippers, planers, etc.)

Compound Drives and Power Engaged Power Take-Off applications must have written factory review.

Twin Disc, Incorporated reminds users of these products that their safe operation depends on use in compliance with engineering information provided in our catalog. Users are also reminded that safe operation depends on proper installation, operation and routine maintenance and inspection under prevailing conditions. It is the responsibility of users (and not Twin Disc, Incorporated) to provide and install guards or safety devices which may be required by recognized safety standards or by the Occupational Safety and Health Act of 1970 and its subsequent provisions.

United States of America • Australia • Belgium • France • Italy • Singapore • Switzerland

For nearly a century, we've been putting horsepower to work by designing, engineering and manufacturing rugged-duty industrial products. Our products and our reputation are bolted to the most renowned engine manufacturers and equipment OEMs in the world. Our mission is to make your machines and vehicles more productive, more durable, more operator-friendly, more cost-effective. From design and installation consultation through after-sale support, Twin Disc and its distributors are committed to your business. No one knows more about managing horsepower in more ways than Twin Disc.

TRANSMISSIONS • CLUTCHES • PTOs  
PUMP DRIVES • TORQUE CONVERTERS  
GEARBOXES • HYDRAULIC PTO PRODUCTS



**Twin Disc, Incorporated**  
**Racine, Wisconsin 53403 USA**  
**Phone +1-262-638-4000**  
**Fax +1-262-638-4482**  
**www.twindisc.com**

TD-Bulletin-SP314S  
 © 2007, Twin Disc, Incorporated  
 Printed in the USA - 05/2007